

# SMART DRUM BLENDER

## General:

The Smart Drum Blender is designed to blend powders in Matcon Smart Drums.

## Blender & Controls:

The Blender is a stand-alone, floor-mounted unit incorporating a single rotating, cantilever shaft onto which is fixed a hinged clamp for firmly holding Smart Drums.

Once clamped in the Blender, the Smart Drum is tilted to an eccentric axis of rotation to ensure thorough mixing of contents. The tilting action is carried out manually (MT) using a hand wheel. An automatic tilting (AT) option is also available.

The control system is integral to the main drive housing. Standard controls include a digital timer displaying "completed" and "remaining" blend times. Rotation speed is fully adjustable by frequency inverter (Min 4RPM, Max 25RPM).

Controls also include automatic return of Smart Drum to vertical and a button to "invert".

The Blender may be manufactured in Carbon Steel (CS) or Stainless Steel (SS) and comes in three model sizes to suit the sizes of Smart Drum being handled. Each size is available in standard and heavy duty (HD) versions - see table overleaf.

## Smart Drums:

Standard sizes of Smart Drums are shown in the table overleaf.

Note that Smart Drums include a Matcon Cone Valve for guaranteed and controlled discharge of powders. A Transport Cap is manually attached to the Smart Drum outlet before blending to secure the Cone Valve.

When selecting Smart Drums for blending, typically between 15% to 35% of free air volume should be allowed for material to flow during blending.

Smart Drums have fork channels for mechanical handling.



Blending



Loading

## Safety:

Rotating equipment is dangerous and it is necessary to ensure operators cannot be injured by the Blender when in operation.

A safety interlock is pre-wired into the Blender controls as standard.

On request Matcon can provide a Safety Cage (in either carbon steel or stainless steel) which is electrically interlocked to prevent operation of the system unless closed.

Alternatively, the user may provide suitable safety screen, chains, light beams etc which are connected into the standard electrical interlock.

The Blender control panel includes an Emergency Stop button.

Standard units are for "Safe Area" use. ATEX rated units can be supplied on request.

## TECHNICAL SPECIFICATION

(All data is approximate and not to be used for detailed planning)

### Blender

Materials of Construction	
Blender & Cage SS	Stainless Steel sheet AISI 304, welded, glass bead blasted.
Blender & Cage CS	Carbon Steel sheet, welded, thermo-lacquered, colour blue.

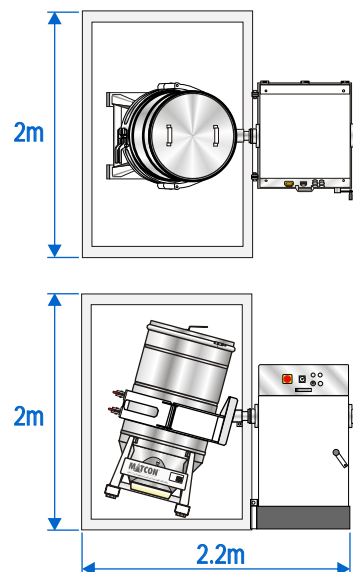
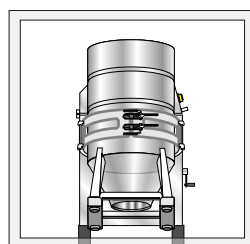

Blender	SDB1 MT & AT	SDB2 MT & AT	SDB3 MT & AT	SDB1-HD MT & AT	SDB2-HD AT only**	SDB3-HD AT only**
Smart Drum Sizes (Ltr)	150	150, 300	150, 300, 450	150	150, 300	150, 300, 450
Power (see note * below)	1.1 kW, 1ph, 230V, 50/60Hz	2.2 kW, 3ph, 400V, 50/60Hz	2.2 kW, 3ph, 400V, 50/60Hz	2.2 kW, 3ph, 400V, 50/60Hz	3.0 kW, 3ph, 400V, 50/60Hz	3.0 kW, 3ph, 400V, 50/60Hz
* Power supply shown is standard. Other supplies available on request.						
Weight (Kg)	220	300	320	300	370	400
Max Load (Kg)	200	400	400	400	800	800
** Manual Tilting model is not available for SDB2-HD and SDB3-HD - only Automatic Tilting.						

### Smart Drums

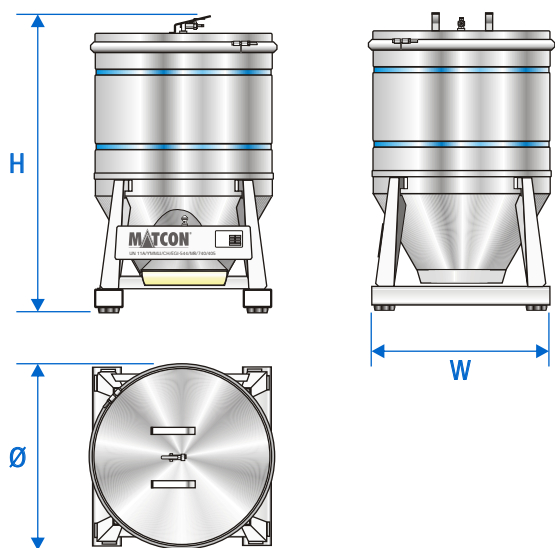

Capacity Ltr	Dimensions H x W x Ø (mm)	Weight (kg)
150	784 x 715sq x 768	50
300	1163 x 715sq x 768	75
450	1542 x 715sq x 768	85

This information and data is provided for illustrative purposes only and does not form part of any contract or agreement. The information and data may be updated and changed from time to time.